



PVC-U Systems

# Maintenance Handbook



TRUST IN QUALITY



# Introduction

Dear Customer

Congratulations on your new installation. We trust you will enjoy trouble-free use for many years to come.

As with any equipment, to obtain complete satisfaction it is advisable to carry out basic, regular maintenance.

This booklet contains useful tips and information to help you get the best from your investment.

In the event of any difficulties, your installer or local independent manufacturer will be pleased to help you.

As our policy is one of continuous improvement in products, methods and materials, changes in specification may be made from time-to-time without prior notice.





# Contents

Looking after your windows and doors 04

Cleaning PVC-U Profiles 06

---

Maintenance 08

Condensation 11

Security 13

Glazing 14

---

## Window Styles

Casement Windows 17

Tilt & Turn Windows 20

Vertical Sliding Sash Windows 22

Fully Reversible Window 24

Window Hardware 26

---

## Door Styles

Residential Door 29

Sliding Patio Door 31

# Looking after your windows and doors

Follow these tips to keep your windows and doors in top condition.

- Carry out routine maintenance on your windows and doors at least twice a year. You may need to do this more frequently in exposed areas.
- Wash down all parts of your windows and doors that are exposed when closed with warm soapy water using a soft cloth, then dry thoroughly.
- Wipe clean any parts that are exposed when the windows and doors are open to remove any grime, insect remains or old lubricant.
- Regularly clean glass with a clear liquid spray glass cleaner.
- Never paint PVC-U window frames.
- Avoid cleaning agents that are abrasive or contain ammonia, particularly on handles and metal fittings.
- Pay special attention to drainage channels, keeping them clear and free from blockages.
- Apply 3-in-1 oil to any moving parts and fixings to keep locking mechanisms in working order.
- Use a suitable acid- and resin-free grease such as petroleum jelly on sliding bars, gears and face plates.
- Maintenance of friction stays is important. Follow guidelines for lubrication and adjustment.

Note: Hardware should be operated and maintained strictly in accordance with manufacturers instructions.





# Cleaning PVC-U Profiles

Cleaning cloths should be unbleached cellulose/cotton material. Do not use cloths containing synthetic fibres.

Contamination	Cleaning Method		
	Scrape off & polish using a dry cloth	Clean with water and mild detergent	Clean with non-abrasive household detergent & water
Pencil			✓
Emulsion paint	✓		
Felt pen			✓
In-organic grease			✓
In-organic			✓
Plaster	✓	✓	
Woodstain		✓	
Ball-point pen			✓
Cellulose paint	✓		
Rust			✓
Soot			✓
Cement mortar		✓	
Wax pen		✓	



# Maintenance

---

## Glass Cleaning

- Glass is easily scratched and it is, therefore, recommended that hand jewellery is removed prior to cleaning.
- Any proprietary household cleaner may be used with a soft cloth and it is recommended that heavy external grime be initially removed with a solution of soap and water.
- Laminated glass, or glass containing Georgian bars, is cleaned in exactly the same manner.

## Leaded Glass Cleaning

- In this type of glazing, lead strips are bonded to the outside and inside of the external pane of glass.
- Take care when cleaning leaded lights as excessive pressure might dislodge the lead from the glass surface.
- The use of warm soapy water and a soft cloth, moderately applied will prove an adequate cleaning method.

## Scratched Glass

- If scratches occur, most can be removed with jewellers' rouge, or an equivalent rubbing compound.

(See pages 14 & 15 for further information on glazing.)

## PVC-U Frame Cleaning (Avoid all solvent-based or abrasive cleaners).

- Wash frames with a soap and water solution periodically to remove any grime and atmospheric deposits.
- If required, clean with a non-abrasive cleaner to remove any stubborn blemishes.
- Take care not to disturb sealants.



## Conservatory & Porch Roof Cleaning

(Avoid all solvent-based or abrasive cleaners).

- Roofing, rafters and PVC-U components fitted to these structures must be cleaned in a similar manner to PVC-U frames.
- Clear gutters of leaves and debris as required to avoid overflow of rainwater and ensure unobstructed drainage.
- Wash roof panels with soap and water solution periodically to remove grime and atmospheric deposits.

Do not walk on conservatory roofs.



## Weatherseals

- During cleaning and general maintenance ensure that any hand-inserted weatherseals fitted to your products do not become dislodged from their grooves. Should this occur, slide back into position immediately to avoid damage when the product is closed.
- If the weatherseals are broken or damaged and draughts are felt around the product, ensure prompt replacement by contacting your installer.

## Drainage

- Your windows and doors are designed with an in-built drainage system, comprising slots within the thresholds that allow any water ingress to flow to the outside. To ensure an efficient system these slots must remain unblocked.
- Periodically, remove dirt, clear the drain slots (situated in the frame rebates) and check drainage operation by flushing through with water.

## Lubrication

To attain optimum performance, it is essential that all hardware is lubricated every 6-12 months (depending on location).

For lubrication of hardware etc, use 3-in-1 oil for moving parts and petroleum jelly where indicated in the product specific lubrication instruction.

## Silicone Seal

Please note that some discolouration of the Silicone seal is a natural occurrence and cannot be avoided.

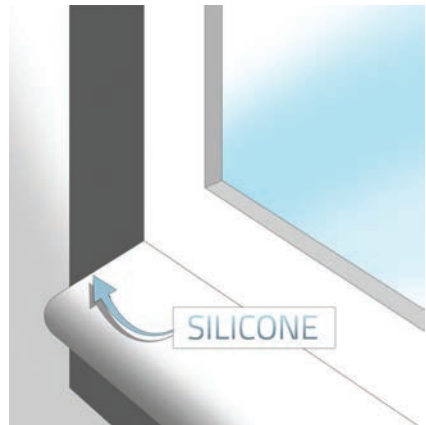

# Condensation

---

In general climatic conditions water vapour is continually present in the atmosphere. In the home this natural water content is increased by normal living activities that create steam, such as cooking, bathing, washing, boiling a kettle etc, plus the basic activity of breathing.

The water vapour remains undetectable while floating in warm air; but upon contact with cold surfaces, windows, mirrors, tiles etc, condensation occurs and the vapour turns to water droplets.

Fitting double or triple glazing does not necessarily solve underlying condensation problems.

Traditional house construction allowed the escape of this water vapour through natural ventilation - open flues of coal fires, air bricks and ill-fitting windows and doors.

The drive to conserve energy and reduce heating costs has led to the sealing of homes, resulting in trapped water vapour and increased problems of condensation.

The advent of more energy-efficient glass can, in certain circumstances, lead to condensation being evident on the OUTSIDE of the window.



## Ventilation

Provide natural ventilation whenever possible by:

- Opening a window/trickle vent.
- Fitting a ventilator/extraction unit in the kitchen and bathroom.
- Fitting wall vents to provide air flow.

NB: Security should be borne in mind when leaving a window open.

## Heating

- Maintain some permanent heat in the house during cold weather. Marginally increase the temperature in areas where condensation is a particular problem.
- If possible, fit radiators under windows to maintain the temperature of the inside pane of your glass.

## Circulation

Water vapour will easily drift on convection currents far from where originated.

- Keep internal doors to kitchen and bathroom areas closed and draught-sealed, where possible, to prevent the excessively moist air in these rooms being transferred to other areas of the house.
- Bedroom windows should have a night ventilation facility to provide air movement. Ideally, if bedroom doors are closed, a ventilation grille should be installed in or above the door also.
- To ensure air flow in the vicinity of windows, curtains should be a minimum of 150mm (6") away from the window, with suitable gaps, top and bottom, to allow circulation.







# Security

---

Your windows and doors have been specifically designed to include a variety of security features to protect your home and family against intrusion.

We recommend a number of sensible precautions which should be taken to gain full advantage of the security features available with your windows and doors:

- Never leave a window open when your home is unattended.
- For added protection, lock all windows in the closed position and remove the keys.
- To provide adequate means of escape in the event of any emergency, we recommend that keys to all windows are located adjacent to the window, but out of external view.
- When leaving the house unattended or at night, ensure door handles are fully lifted and that the keys are turned to throw and lock all deadbolts/hookbolts for full security.

# Glazing

---

All glazed units are susceptible to a degree of surface damage during the glass manufacturing process. Certain imperfections in the glass cannot be avoided, even in the most carefully controlled production environment.

Blemishes and imperfections are inherent in all glazing, and are acceptable within the highest standards of the industry.

We wish to draw your attention to the following extract from an industry accepted standard, relating to glass generally.

1. Transparent Glass, used in the manufacture of glazed units is identical to that used in traditional single-glazing and will therefore have a similar level of quality.
2. The glazed unit shall be viewed from the room side, standing at a distance of two metres (6'6" approx) in natural daylight and not in direct sunlight. The area to be viewed is the normal vision area, with the exception of a 50mm (2") wide band around the perimeter of the unit.

NB: The appearance of modern low 'E' glass units, in certain sunlight, may present a "smokey hue". This appearance is perfectly normal. It is due to the metallic layer on the inner surface of the outer pane of glass.

3. Flat Transparent Glass shall be deemed acceptable if the following phenomena are neither obtrusive or bunched:
  - a. Totally enclosed seeds.
  - b. Bubbles or blisters.
  - c. Hairlines or blobs.
  - d. Fine scratches, not more than 25mm (1") long.
  - e. Minute embedded particles.
4. Obtrusiveness of blemishes shall be judged by looking through the glass and not at it, under normal lighting conditions as described in point 2.

Extracted from the Glass & Glazing Federation Standards.

## Glass Defects

Your installer uses only the highest quality float glass available, whether laminated, toughened or annealed, which conforms to the requirements of BS 6262.

## Patterned Glass

This glass originates in very large sheets and due to spacing repetition, centralisation of any design in a specific window, cannot be guaranteed.





# WINDOWS





# Casement Windows and Flush Casement Windows

Casement windows open outwards, with friction hinges holding them in the desired position. Locking is achieved via the mushroom cams and/or the shootbolts of the locking mechanism, engaging into keeps fitted to the outer frame.

These keeps usually have secondary slots, which provide a 'night vent' position. This allows the window to be slightly open, providing ventilation.

## Operating Instructions

- If fitted, turn key or depress button to unlock the locking handle. If handles with different key/button operating sequences are fitted, check with your installer for instructions.
  - Rotate the handle through 90° to disengage locking mechanism and open by pushing outwards.
  - To engage the window in night vent position, open the window to approximately 15mm and then return the handle to its locking position. If you feel slight resistance do not try to force the handle. Simply move the window slightly until you find a point where there is no resistance, and close.
  - Check the window is securely in the night vent position by pushing gently on the vent - if held securely it should not move.
  - Accessible windows should not be left in night vent position when the property is unoccupied.
- To close, reverse the procedure by pulling the window closed and turning the handle back to its original position. Handles can be deadlocked using the key provided.

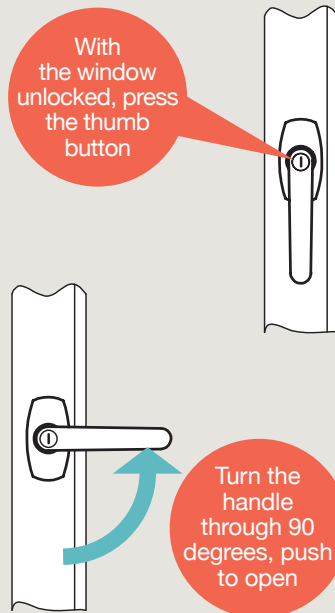

Note: Hardware should be operated and maintained strictly in accordance with manufacturers instructions.

## Friction Hinges

Friction can be increased or decreased by adjusting a screw. Turn in a clockwise direction to increase friction. Take care not to over-tighten.

## Egress Friction Hinges

Egress hinges allow the window to be opened to 90°. Some egress hinges incorporate an easy-clean system, whereby the vent can be slid sideways to allow external cleaning from inside.

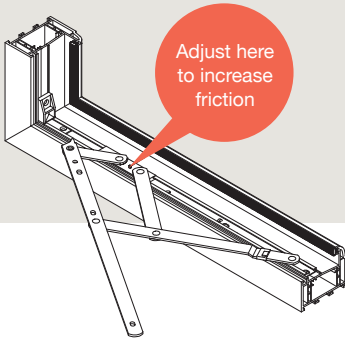

To utilise the easy-clean facility, open the window normally, then press and hold down the button to release the restrictor hinge. Slide the vent across to allow egress.

## Ventilation Control

Windows must be fitted with trickle vents, located at the top of the frame. This is designed to control ventilation and minimise condensation build-up. Simply open or close the ventilator. No maintenance is required.

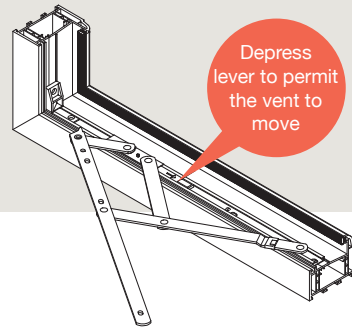

## Maintenance Instructions

### Friction Hinges

Keep friction stay track free from dirt and grime and keep the hinge mechanism clean. Lubricate metal parts regularly with 3-in-1 oil, concentrating on the pivot points.

### Locking Mechanism

Lubricate as required. Keep sliding mechanism free of dirt and lubricate each slot with 3-in-1 oil.

### Keeps

Lubricate the slots of the keeps with petroleum jelly as required.

### Espagnolette Handles

Clean and lightly oil moving parts



# Tilt & Turn Windows and Flush Tilt & Turn Windows

These versatile, inward opening windows are capable of two modes of operation:

- Tilt mode for ventilation
- Turn mode for cleaning and emergency exit.

'Tilt & turn' relates to the sequence of operation which is designed, for safety, to select tilt mode first, followed by turn mode.

Locking is via a series of cams or espagnolettes, located on a sliding

mechanism around the edge of the window. When shut and the 'closed' handle position is selected, the cams engage into keeps fitted around the outer frame, to lock and provide weather sealing.

## Operating Instructions

There are three handle positions: 'closed', 'tilt' and 'turn'. The operation sequence starts with the window in the closed position (handle vertically downwards).

Note: The window must always be fully shut before changing the handle position.

- If required, turn key to unlock the handle.
- To select tilt mode, rotate the handle through 90° and gently pull the window inwards. The bottom will remain hinged to the frame, while the top tilts inwards to allow ventilation.
- To close the window, push shut and secure by turning the handle back to the closed position.

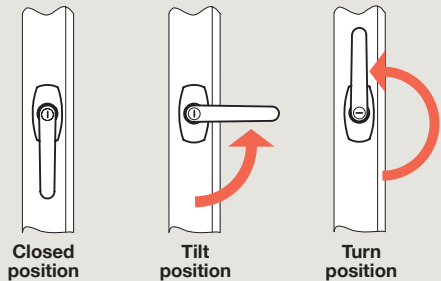

- To select turn from the tilt mode, close the window and rotate the handle upwards from its horizontal position and pull the window inwards. The side remains hinged to the frame, while the window may be opened inwards to allow cleaning from inside.



- To select turn from the closed position, rotate the handle through 180° to the upright position and pull the window inwards to allow cleaning.
- To close the window, reverse the previous procedure. The turn position is for cleaning only and should not be used for ventilation.

### Switch Barrier

The switch barrier (adjacent to the handle on the locking mechanism) is a safety device which ensures that only one mode, 'tilt' or 'turn', can be selected at any time, by securing the handle into the selected mode while the window is open.

Avoid pressing the switch barrier, as this releases the handle which could allow it to be accidentally rotated to the alternative mode, resulting in the window disengaging from its gear. Always firmly push the opening vent into the window frame before changing the handle position.

### Ventilation Control

Windows must be fitted with a trickle vent unit, located at the top of the frame. This allows you to control ventilation and minimises any condensation build-up. Simply open or close the ventilator. No maintenance is required.

## Maintenance Instructions

### Tilt & Turn Mechanism

Keep the locking mechanism free from dirt and grime. Lubricate all locking points regularly with 3-in-1 oil to maintain smooth operation.

### Keeps

Lubricate the faces of the keeps with petroleum jelly as required.

### Handles

Clean and lightly oil moving parts.

Note: Hardware should be operated and maintained strictly in accordance with manufacturer's instructions.

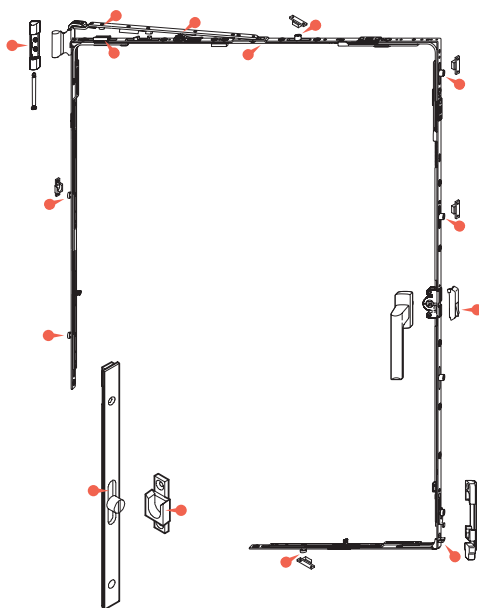

# Vertical Sliding Sash Windows

These windows deliver a true authentic appearance that perfectly replicates a timber box sash window. Its period looks make it ideal for heritage projects, whilst it's equally at home in modern buildings where its classic looks add elegant visual interest.

## Operating Instructions

The window is opened for ventilation by unlocking the snail cam(s) located on the top face of the bottom sash using the key provided (if key locking versions are fitted). Turn the cam(s) until released from the keep(s).

The bottom sash may now be slid upwards and/or the top sash may be slid downwards.

To close the window slide both sashes fully closed and re-engage the snail cam(s).

The window is opened into the cleaning position by opening the bottom sash to approximately 100mm (as previously described). Both tilt catches are then slid inwards releasing the top of the sash. This can then be pulled inwards and rested on its restrictor to allow safe cleaning of the glass from inside the building.

The top sash can now be slid down. Both of its tilt catches are then slid inwards releasing the top of this sash. This can then be pulled inwards and

rested on its restrictor to allow safe cleaning of the glass from inside the building.

## Ventilation Control

Windows must be fitted with a trickle vent. This is designed to control ventilation and minimise condensation build-up. Simply open or close the ventilator. No maintenance is required.

## Maintenance Instructions

The hardware requires simple lubrication. An application of 3-in-1 oil will keep the locking mechanisms in good working order.



Note: Hardware should be operated and maintained strictly in accordance with manufacturer's instructions.



# Fully Reversible Windows

These windows rotate through 180° to allow internal cleaning of external panes. Safety catches limit the initial opening and operate again at full rotation. Locking is achieved by an espagnolette mechanism. Lock keeps also allow a 'night vent' position, providing more secure ventilation.

## Operating Instructions

### To open for ventilation

Unlock the handle and rotate 90°. Push the window outwards - it will stop in the first restricted position. If more ventilation is required, depress the button on the left-hand side, marked 'PRESS' allowing the window to be pushed open to the next position.

### To open for night vent

If less ventilation is required, rotate the handle upright to 90°, open approximately 20mm and close handle to engage night vent slots.

### To close

Depress the button on the left-hand side, pull shut, and secure by returning the handle to the closed position.

### To rotate for cleaning

The window is moved into the reversed position. This is done by opening as above for ventilation but at the second position depress the button again and push the window

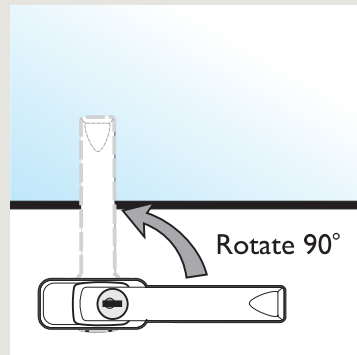

further open. The head of the window can now be gripped and pulled down to fully reverse the window. It should click into place in this position to provide safe cleaning from inside the building. Do not attempt to clean the window in the reverse position until the safety catch is engaged.

### To close after cleaning

Depress the button located on the left-hand side, marked 'PRESS' to disengage the catches. Push the top of the window outwards. The bottom can now be gripped and the window pulled into the closed position. Use the handle to fully close and lock in place.



1. Night Vent Position

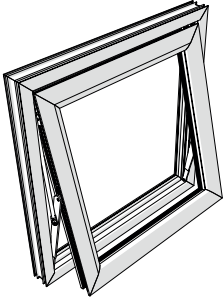

2. Ventilation Position

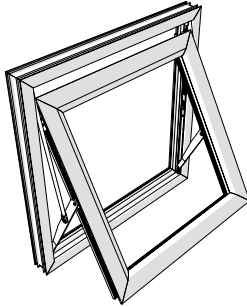

3. Cleaning Position

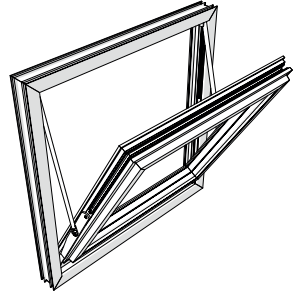

## Ventilation Control

Windows must be fitted with a trickle vent, located at the top of the frame. This is designed to control ventilation and minimise condensation build-up. Simply open or close the ventilator. No maintenance is required.

## Maintenance Instructions

- All pivot points in the hinge should be kept lightly oiled. Use 3 in 1 oil.
- Lightly grease the vertical tracks.
- Lubricate the keeps with petroleum jelly.

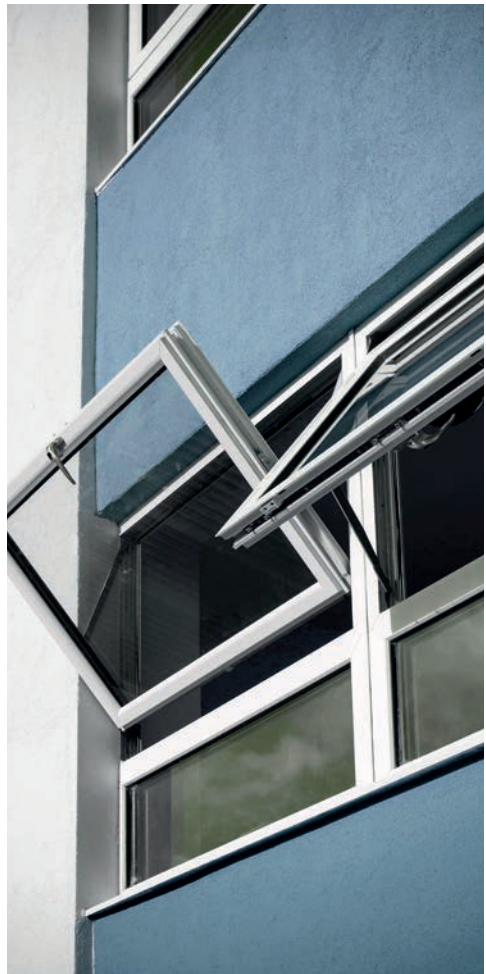
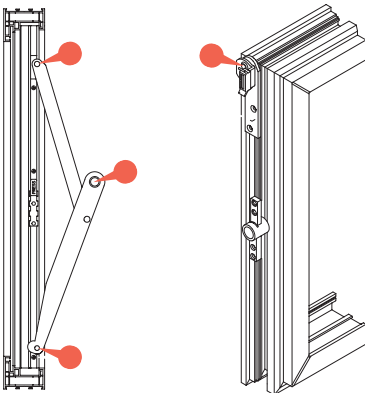

# Window Hardware

## Restrictor

If fitted, the restrictor limits the opening of the window to control ventilation. The restrictor may be disengaged to allow the window to be fully opened. There are two main types of restrictor, the standard casement restrictor and the security restrictor.

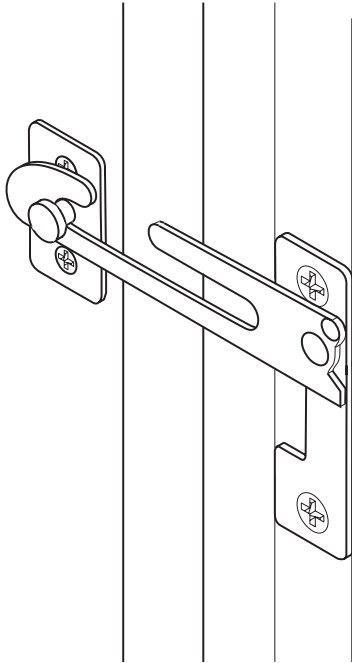

Casement Window  
Restrictor-Engaged

## Standard Casement Restrictor operating Instructions

### To open - restricted

- Operate handle and open window. The restrictor arm will limit opening.

### To open - fully

- Once opened to the restricted position, close the window slightly and manually release the restrictor by lining up the slot opening with the striker post. While holding the restrictor latch, open window fully.

### To close

- Close the window in the normal manner. The restrictor will automatically re-engage.



## Security Restrictor Operating Instructions

A special key is supplied to provide adjustment for the swinging arm and to enable the unit to be locked.

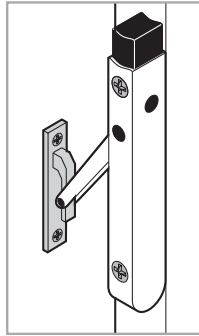

### To lock restrictor

- Insert special key at the back of the unit and rotate clockwise half a turn.

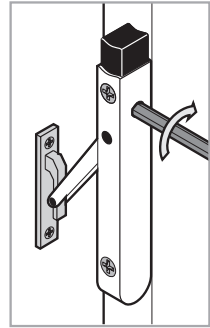

Note: To provide adequate means of escape in the event of any emergency, we recommend that keys to all windows are located adjacent to the window, but out of external view. engage.

### To open - restricted

- Select required mode and open window. Restrictor arm will limit opening.

### To open - fully

- Close window.
- While holding down control button, re-open window.
- Release button as soon as window has cleared frame.

### To close

- Close the window in the normal manner.
- The restrictor will automatically re-engage.

### To adjust swinging arm

- Insert the key into socket at the side of the unit and rotate clockwise to tighten swinging arm or anti-clockwise to loosen.

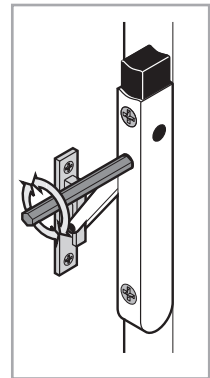

Note: that in the unlikely event that adjustment is needed, only a small movement (1/4 turn) will be required.

# DOORS





# Residential and French Doors

Doors can be fitted with lever/lever handles that limit outside opening by use of a key, or lever/pad handles allowing external opening by handle movement.

High-security locking systems generally comprise multipoint hook/deadbolts of various types, and a latch lock, which engages into keeps fitted to the frame jamb.

The deadbolts are engaged by lifting the handle.

## Operating Instructions



### To lock

1. Close the door to engage latchlock.
2. Fully lift the handle or pad to engage top and bottom deadbolts/hookbolts/rollers.
3. Insert key into the cylinder and turn one complete revolution to activate centre deadbolt.

If the key will not turn, lift handle or pad to maximum position and then turn key.



### To unlock

1. Insert key and turn one complete revolution.
2. Depress handle or pad to disengage top and bottom deadbolts/hookbolts/rollers.
3. With lever handle, door will open.
4. With pad handle, continue to turn key to open.

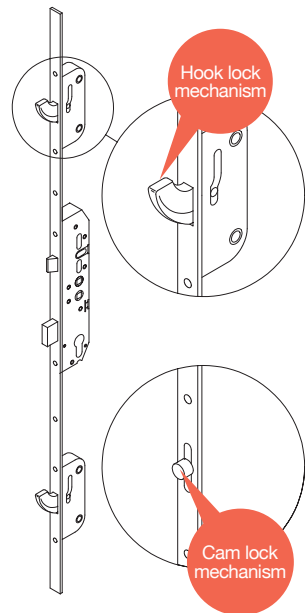

# Maintenance Instructions

## Lubrication - as required

### Locking Mechanism

- With the door open, lubricate the deadbolts/ hookbolts/rollers and latchlock with 3-in-1 oil.

### Hinges

- Clean and lightly oil hinge pins. If hinges are external (Open-out door) lubricate every six months.

### Handles

- Clean and lightly oil external moving parts.

### Lock Cylinder

DO NOT LUBRICATE (packed with special grease).

### Double Doors

Dependant on locking mechanism there are two slave door locking options:

#### Full Slave Locking

- A handle operated shootbolt lock operating in the same way as the master door (see page 29).

#### Fingerbolts

- Hand operated fingerbolts are fitted to the top and bottom of the slave door.

Lubrication - As required lightly oil external moving parts.

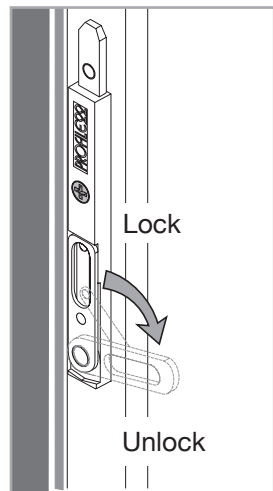
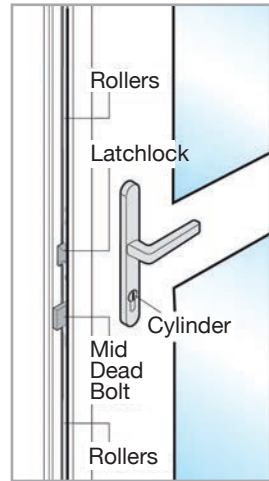

# Sliding Patio Doors

Patio doors are designed to be very low maintenance. The general service and maintenance tasks recommended are simple to carry out and do not require specialist skills, tools or equipment.

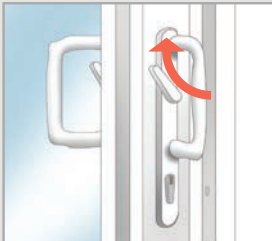

## Operating Instructions

### To lock

- Slide door to fully closed position.
- Lift lever behind handle (hooks will engage to lock the door).
- Turn key to deadlock locking mechanism.

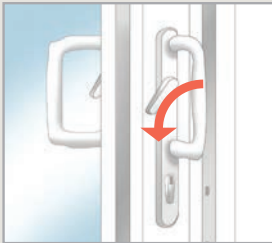

### To unlock

- Insert the key in the cylinder and rotate to unlock the mechanism.
- Depress lever behind handle (hooks will disengage).
- Slide door open.

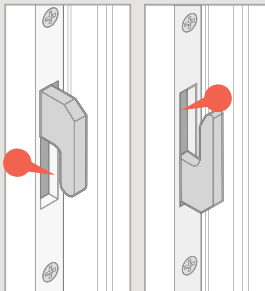

## Maintenance Instructions

### Lubrication - as required

Oil the locking cams and hookbolts of the mechanism.

### Lock Cylinder

Do not lubricate (packed with special grease).

### Bottom Track

Keep permanently free of dirt and obstruction. Ensure that drainage slots are clear of debris.

## Weatherseals

Following the initial installation the weatherseals may require bedding in; causing a slight resistance when operating the door, the application of a silicone spray will aid the smooth operation of the door during this period.



World Group  
Kingdom House  
Brunel Way  
CA1 3NQ  
T: 01228 599777  
E: [hello@world-group.co.uk](mailto:hello@world-group.co.uk)  
[www.world-group.co.uk](http://www.world-group.co.uk)

Epwin Window Systems is a manufacturer of PVC-U and aluminium profile systems, supplied to independent manufacturers and installers who contract to install windows, doors and conservatories. Epwin Window Systems cannot be held accountable for manufacture or installation by independent companies. All information in this publication is provided for guidance only and is given in good faith. As it is company policy to continually improve products, methods and materials, changes of specification may be made from time to time without prior notice. This statement does not affect your statutory rights. © Epwin Window Systems. Part of the Epwin Group Plc. EWS17869